

SHAD

HONDA INTEGRA 750 '14 -'16
HONG76IF

3P
SYSTEM

DESIGNED IN
BARCELONA

1 261972 x1 →
261973 x1 ←

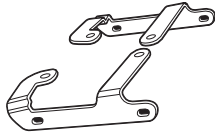

2 261974 x1 →
261975 x1 ←

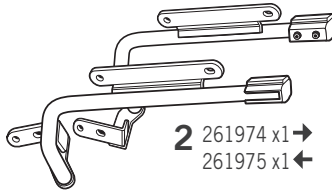

3 304028 x4
M8 x 25 DIN 7380



4 303020 x4
Ø8



5 302024 x4
M8



6 304211 x2
M8 x 15 DIN 933



7 303045 x10
Ø8



8 260213 x4
Ø16 Ø9 x 12



9 304272 x4
M8 x 35 DIN 7380



! WARNING!

GB Do not fully tighten the screws until it is ensured that the KIT is correctly attached and aligned.

E No apretar los tornillos del todo hasta asegurarse que el KIT está correctamente colocado y alineado.

D Ziehen Sie die Schrauben nicht ganz fest, bevor Sie sich nicht vergewissert haben, daß der Bausatz korrekt eingestellt und ausgerichtet ist.

I Non stringere del tutto le viti fin tanto non si è sicuri che il kit è collocato correttamente e allineato.

F Ne pas serrer les vis avant d'être sûr que le KIT est correctement monté et ajusté.

ATTENTION: For a full equip assembly, mount the 3p system before the top master.

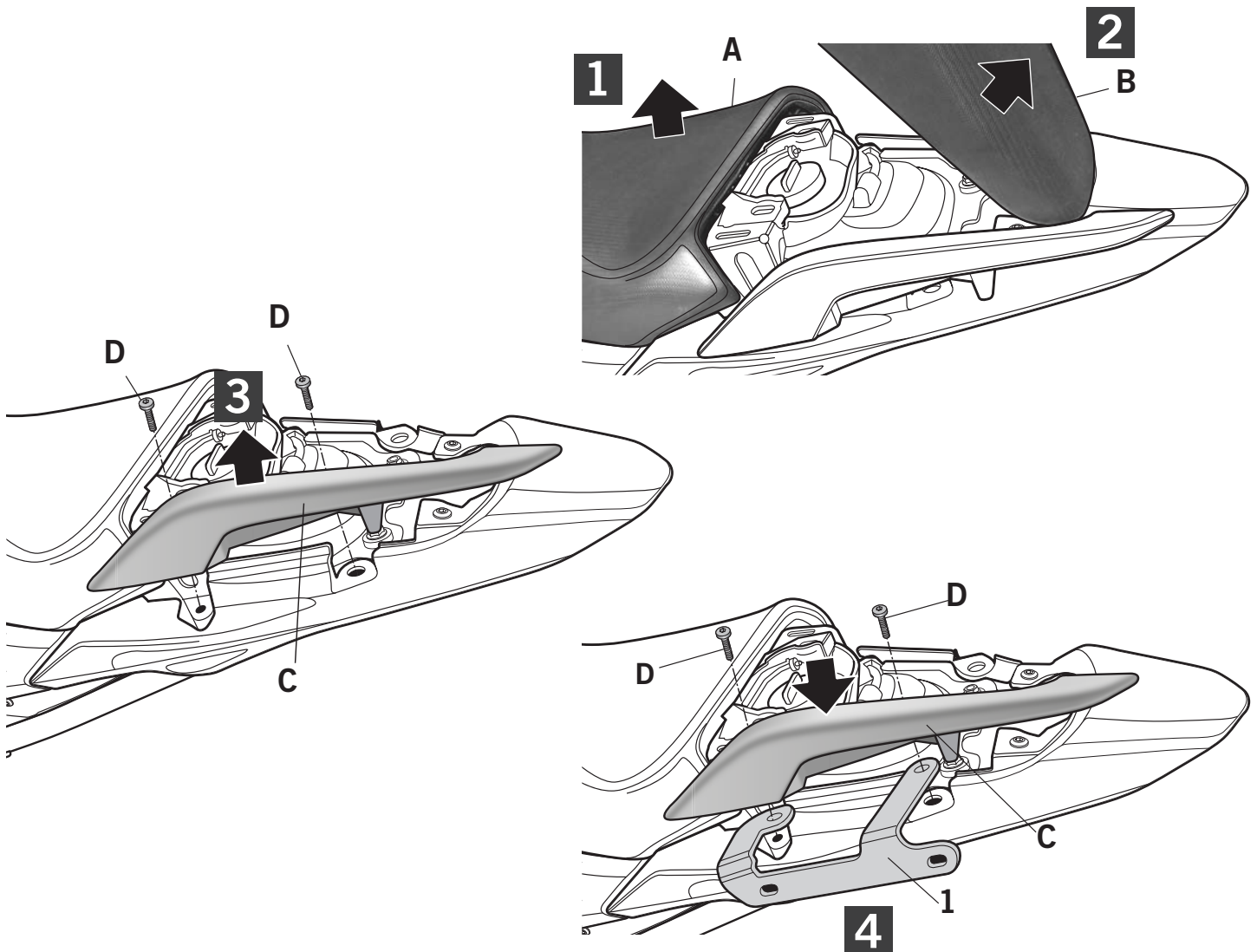

IMPORTANT: Based on European models. For compatibility with models in other continents, check www.shad.es

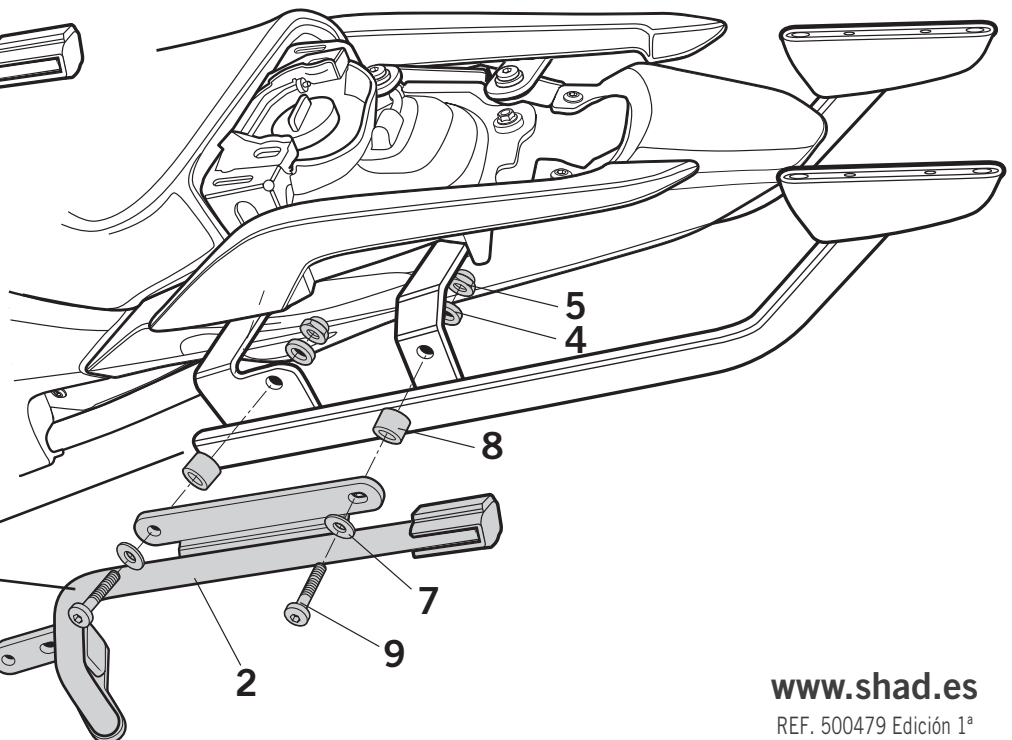
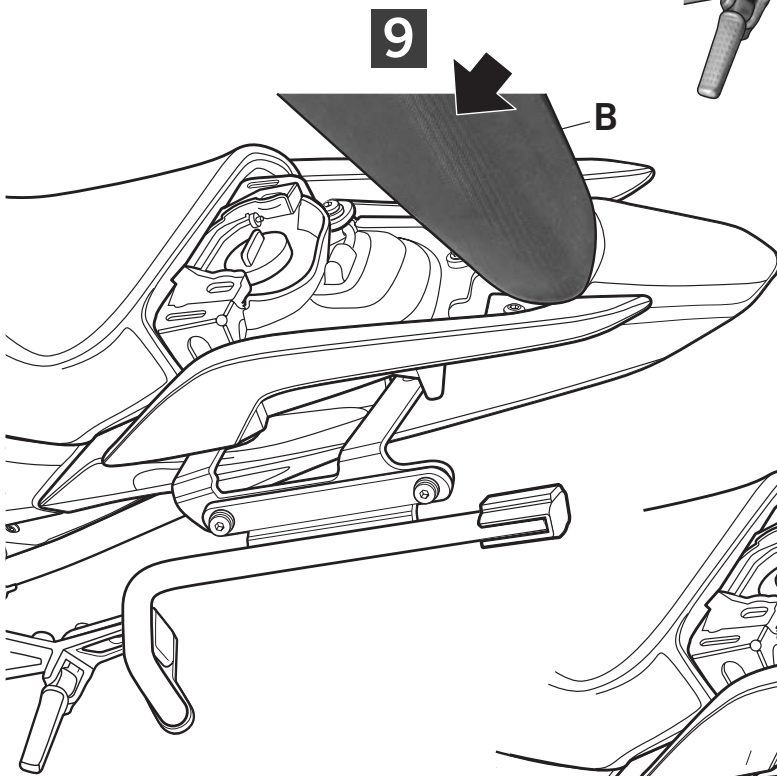
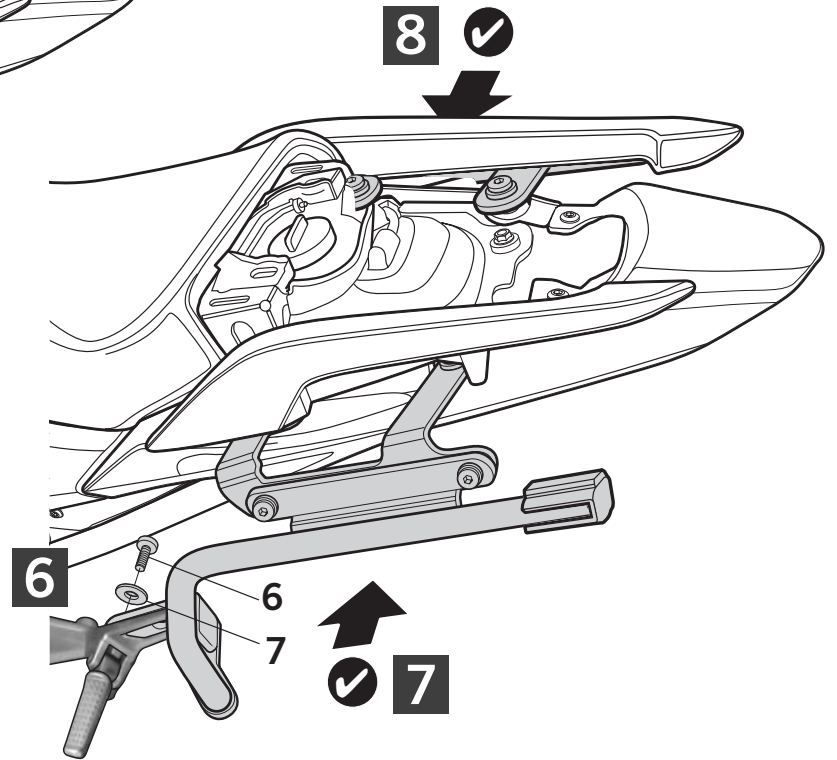
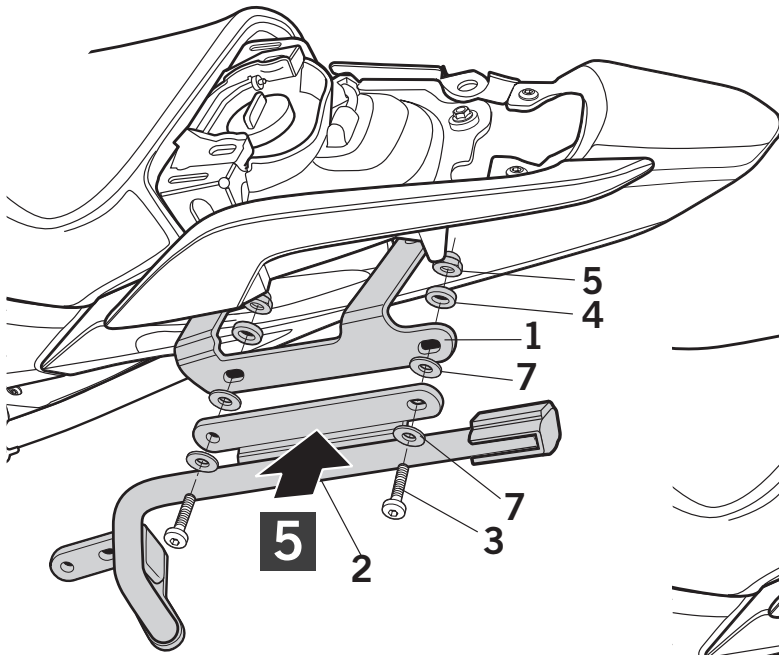

**TOP MASTER
+
3P SYSTEM**